

# Design Documentation



Extracted from Dr. Patricia Lago Lecture  
Notes on Design Documentation

1

## Contents

- Software design
- Design Documentation
- How to decide on relevancy

2

## The process of software design

**Design** is a problem-solving process whose objective is to find and describe a way:

- to implement the functional requirements...
- while respecting the non-functional requirements ...
- and yet deliver 'good' quality

## The result of software design

**A blueprint for the chosen solution (product)**

**A set of design decisions (co-product)**

## Design as a series of decisions

A designer is faced with a series of design issues

- These are sub-problems of the overall design problem.
- Each issue normally has several **alternative solutions** (or design options)
- The designer makes a design decision to resolve each issue.
  - This process involves choosing the best option from among the alternatives.



5

## Taking decisions /1

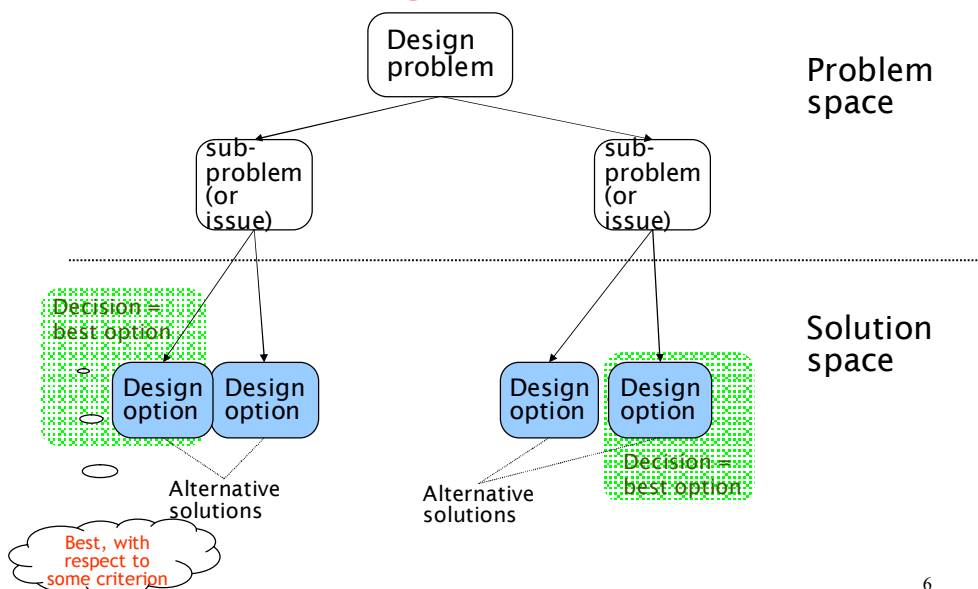

## Design space

The space of possible designs that could be achieved by choosing different sets of alternatives.

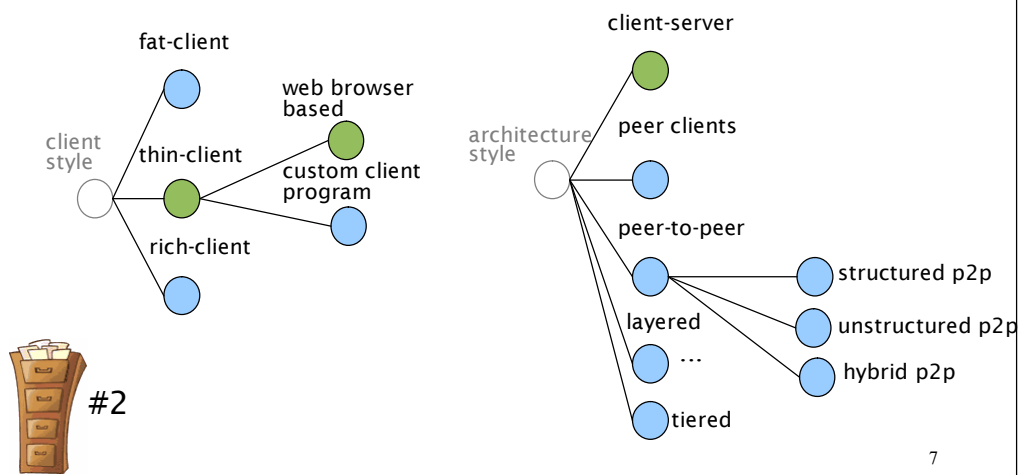

## Decision Problems vs Design problem

*A decision problem is defined as one with a fixed set of options to choose among*

*Design problems are more than complex, they are dilemmas" [Moran&Carroll, Design Rationale, 1996]*

- *Cannot be stated per se*
- *Cannot be solved with a **definitive** answer*
- *Are complex, and full of **implicit** and overstated reasons*
- *Any solution generates (often unknown) "waves of **consequences**"*
- *Design calls for creativity and ingenuity*

## Design rationale

- **Design rationale**
  - The logical reasons given to justify a designed artifact
    - for someone
  - An explanation of why a designed artifact (or some features of an artifact) is the way it is
    - for some question/issue

## Design space analysis

- Represent the design space around an artifact
- Co-product of design
- QOC notation
  - **Questions:** key design issues
  - **Options:** possible answers
  - **Criteria:** assess and compare the *options*

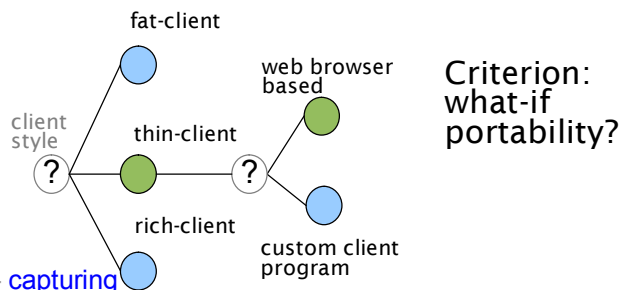

## Example

**QOC3 Which technology should be used by the user to communicate locally with the devices which are located at home?**

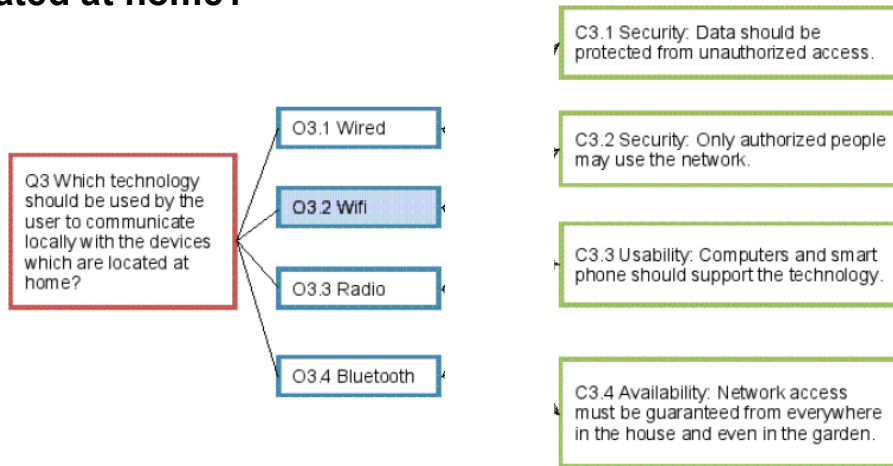

**QOC3 Which technology should be used by the user to communicate locally with the devices which are located at home?**

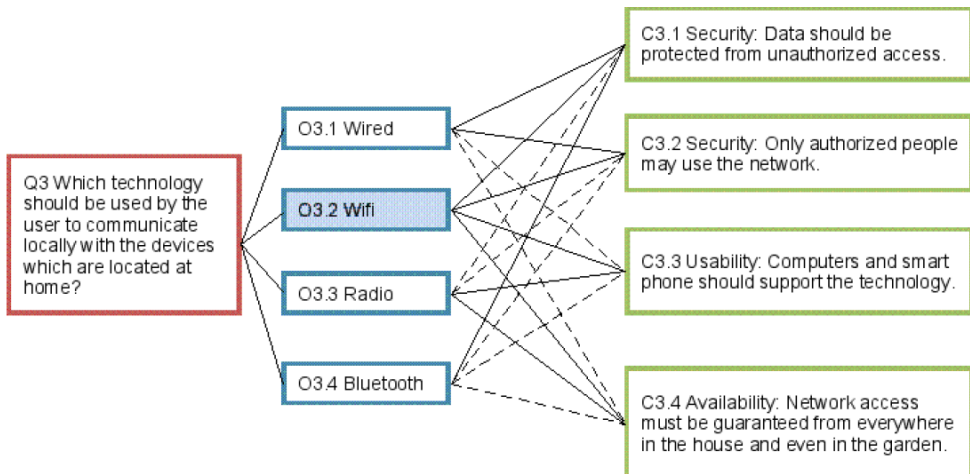

<b>Concern</b>		QOC3 Which technology should be used by the user to communicate locally with the devices which are located at home?
<b>Alternative(s)</b>		O3.1 Wired O3.2 Wifi O3.3 Radio O3.4 Bluetooth
<b>Ranking criteria</b>		C3.1 Security: Data should be protected from unauthorized access. C3.2 Security: Only authorized people may use the network. C3.3 Usability: Computers and smart phone should support the technology. C3.4 Availability: Network access must be guaranteed from everywhere in the house and even in the garden.
<b>Architectural decision</b>	<b>Identifier</b>	#3
	<b>Description</b>	Wifi is secure (WPA2), adaptable (already in use) and a high coverage (much more than the other alternatives). Most devices support wifi nowadays
	<b>Status</b>	Checked by new Italian team members. Criteria's added Numeration of question, options and criteria's added Rationale extended Waiting for approval Italian team members
	<b>Relationship(s)</b>	-
	<b>Rationale</b>	Every device should be controlled from one central point in the house, accessible with a wide range like Wifi has, this device needs to be mobile, like a laptop or PDA.

6

## Capturing in the project 2007

<b>Concern</b>	<b>question</b>	<i>What was the design issue that needed to be solved (by taking a decision)?</i>
<b>Alternative(s)</b>	<b>options</b>	<i>What possible alternatives exist to address the concern?</i>
<b>Ranking criteria</b>	<b>criteria</b>	<i>What criteria have been used to select the decision based on the available alternatives</i>
<b>Architectural decision</b>	<b>Identifier</b>	<i>#&lt;number&gt;</i>
	<b>Description</b>	<i>Short description of the architectural decision taken</i>
<b>chosen option</b>	<b>Status</b>	<i>(by taking a</i>
	<b>Relationship(s)</b>	<i>Indicate existing relationships with other decisions: {forbids, conflicts with, enables, subsumes, is related to}</i>
<b>reason/s</b>	<b>Rationale</b>	<i>Why has this decision been taken</i>

Table 1: Conceptual model for AK design space modeling

- **tables can be complemented with graphical illustrations**

## **Project**

**Project Description and Project Management:  
UMLWEB\_Project.doc**

**Deliverable Template:  
DeliverableTemplate-MWT08.doc**

**AKA template:  
AK\_SPAM.xls**

28

## **Reading**

- **Moran and Carroll Eds. (1996), Design Rationale (Lawrence Erlbaum Associates)**
  - Chapters 1, 3

29